

STRIPE APPLICATIONS

JAN 2026



TABLE OF CONTENTS

SURFACE-MOUNT	01
MAGNETIC SURFACE-MOUNT	02
SURFACE-MOUNTED JUNCTION BOX	03
WALL-MOUNTED ELECTRICAL BOX	05
FLEXIBLE HORIZONTAL CORNER MOUNTING	07
FLEXIBLE VERTICAL CORNER MOUNTING	08
FLEXIBLE HORIZONTAL MOUNTING (HEXAGON)	09
FLEXIBLE HORIZONTAL MOUNTING (DOUBLE HEXAGON)	10
FLEXIBLE HORIZONTAL MOUNTING (MULTI HEXAGON - 2-CIRCUIT)	11
SUSPENSION MOUNTING FROM OCTAGONAL BOX	12
SUSPENSION MOUNTING EXTENSION	14
WALL GRAZE MOUNTING	15
ROTATING WALL MOUNTING	16
HARDWIRING	17

APPLICATION DRAWINGS FOR SURFACE-MOUNT

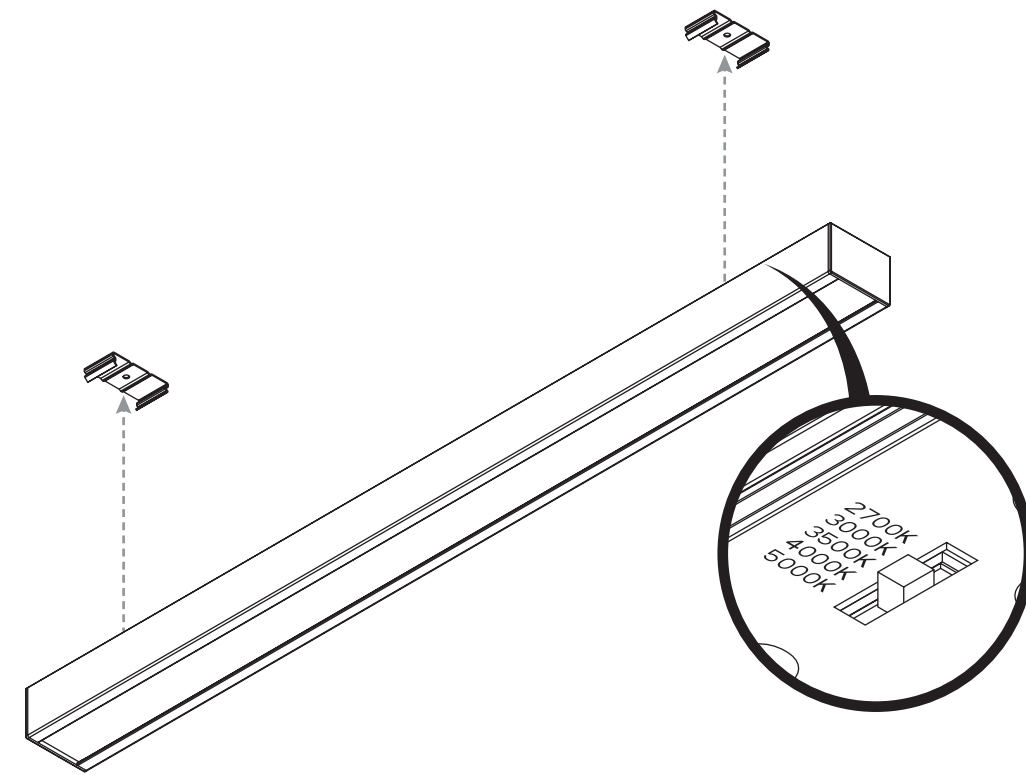

For page 15 of the STRIPE brochure

Factory suggested mounting bracket locations

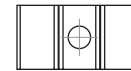

STRIPE18-5CCT / STRIPE24-5CCT

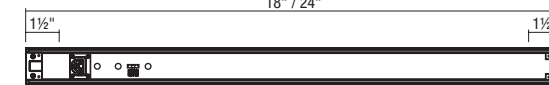

STRIPE36-5CCT

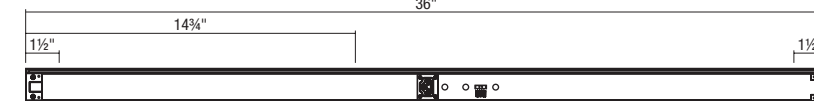

STRIPE48-5CCT

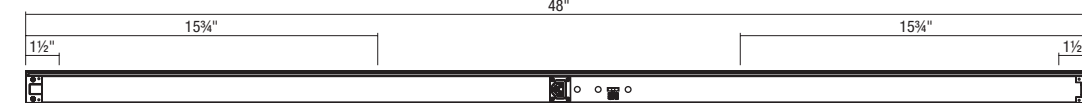

Required components	
Part No.	Quantity
STRIPE-SURMCLIP	1 Set (included)
Choose from the following fixtures	
STRIPE18-5CCT STRIPE24-5CCT STRIPE36-5CCT STRIPE48-5CCT	1

NOTE: Power feed required.

APPLICATION DRAWINGS FOR MAGNETIC SURFACE-MOUNT

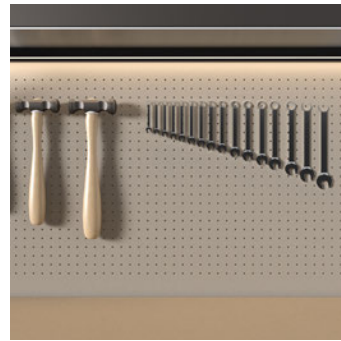
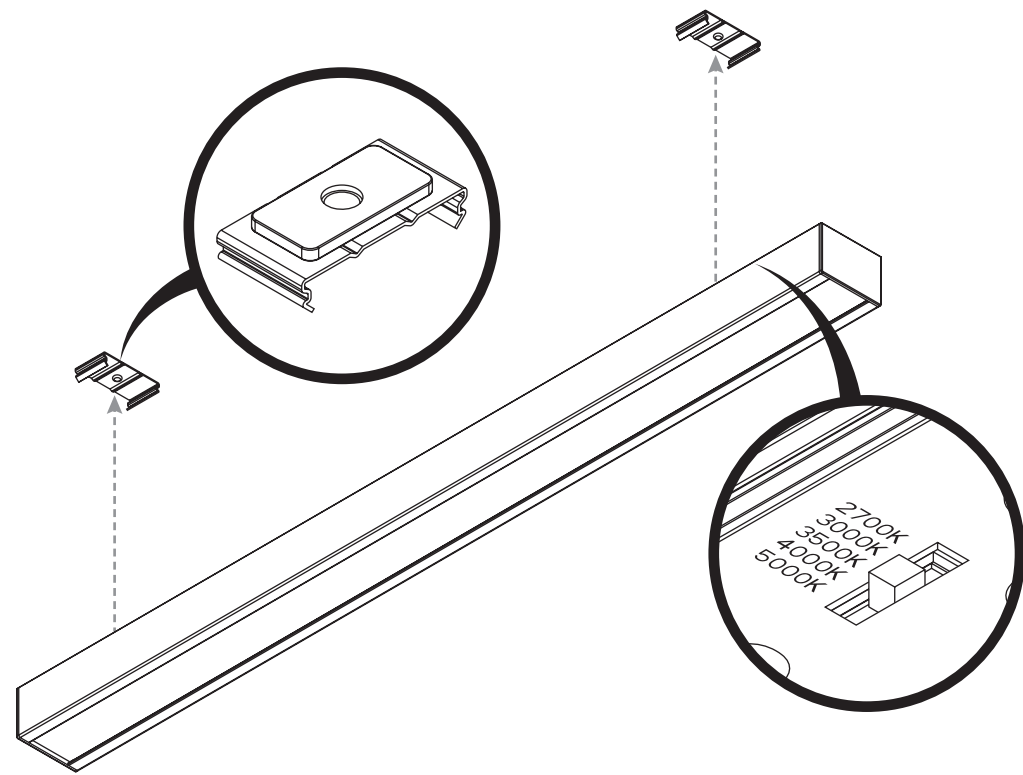

For page 5 of the STRIPE brochure

Required components	
Part No.	Quantity
STRIPE-MAGCLIP	2
Choose from the following fixtures	
STRIPE18-5CCT STRIPE24-5CCT STRIPE36-5CCT STRIPE48-5CCT	1

NOTE: Power feed required.

APPLICATION DRAWINGS FOR SURFACE-MOUNTED JUNCTION BOX

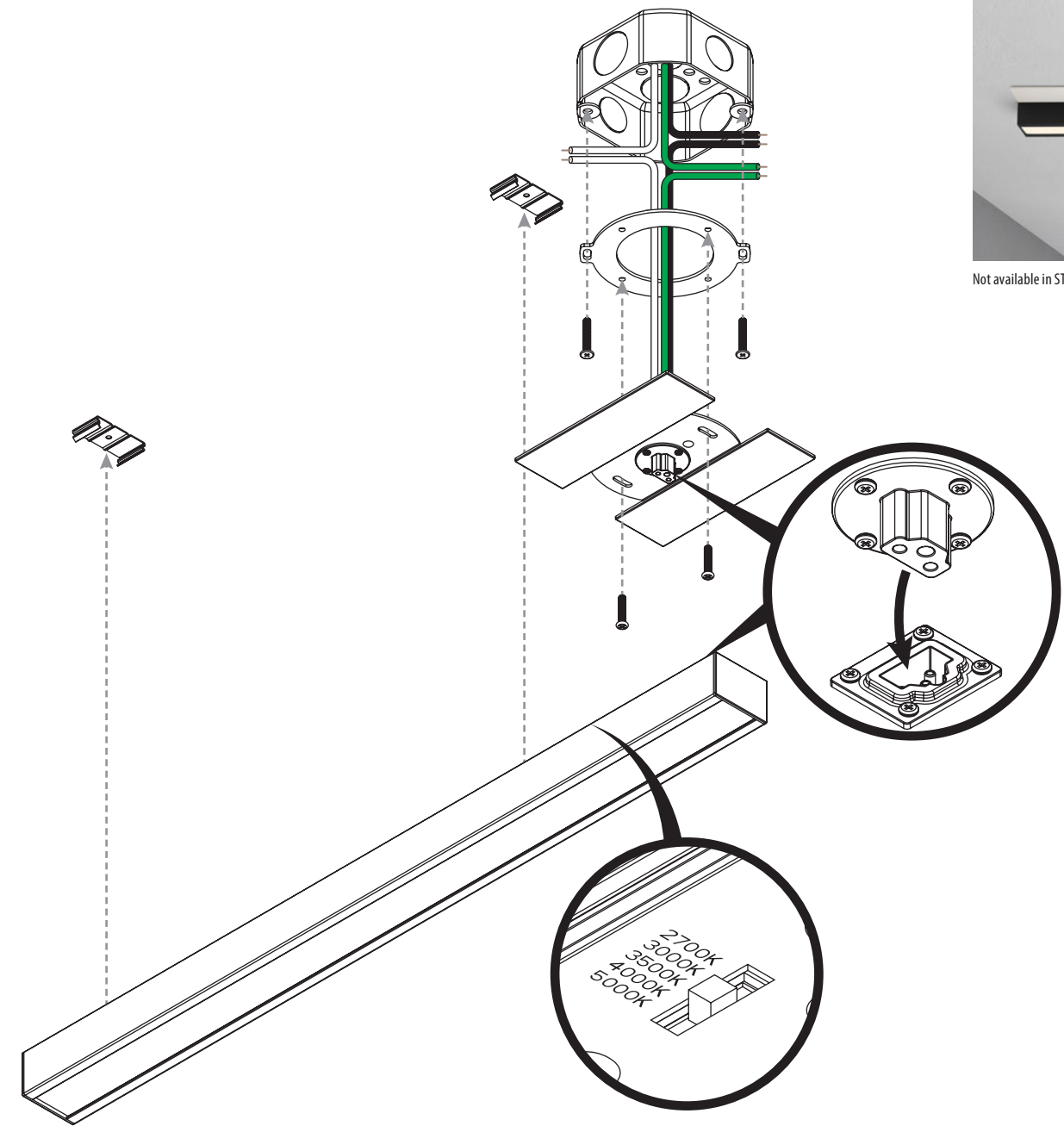

Not available in STRIPE brochure

Factory suggested mounting bracket locations

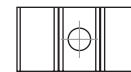

STRIPE18-5CCT / STRIPE24-5CCT

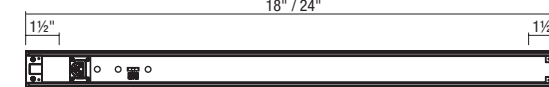

Required components	
Part No.	Quantity
STRIPE-CANOPY	1
Choose from the following fixtures	
STRIPE18-5CCT STRIPE24-5CCT	1

APPLICATION DRAWINGS FOR SURFACE-MOUNTED JUNCTION BOX

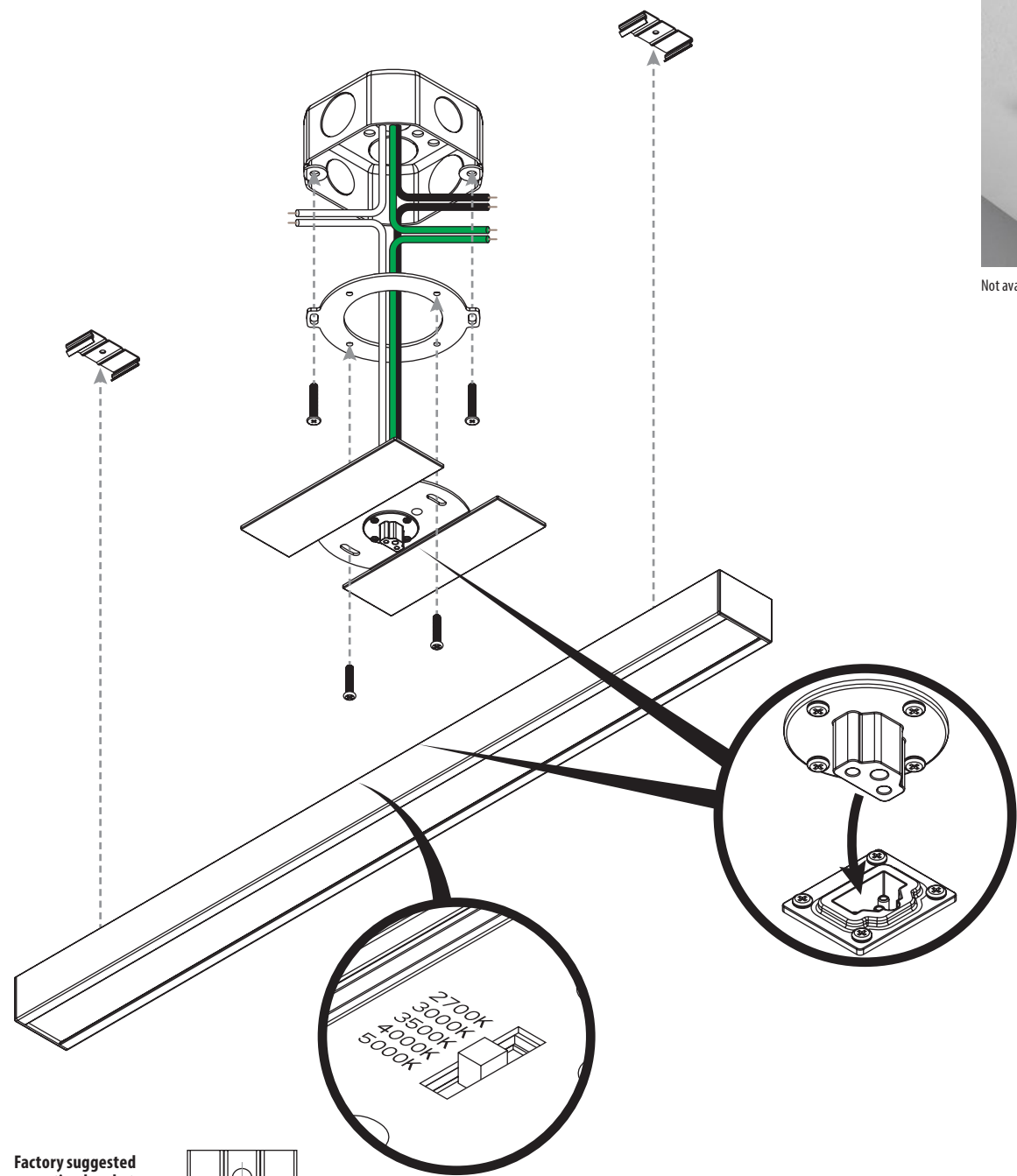

Not available in STRIPE brochure

Factory suggested mounting bracket locations

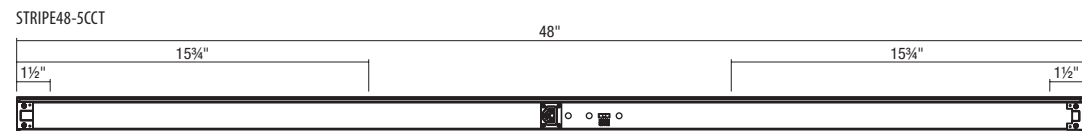
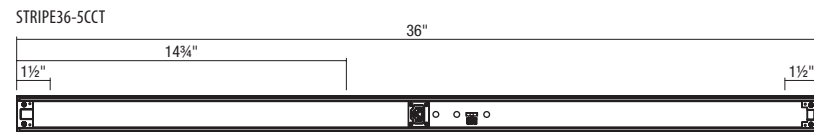
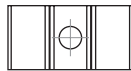

Required components	
Part No.	Quantity
STRIPE-CANOPY	1
Choose from the following fixtures	
STRIPE36-SCCT	1
STRIPE48-SCCT	

APPLICATION DRAWINGS FOR WALL-MOUNTED ELECTRICAL BOX

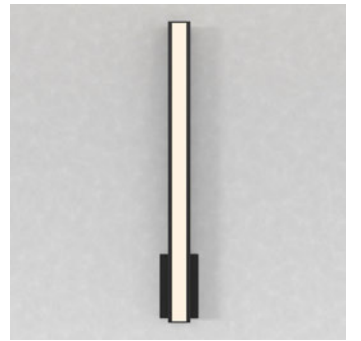
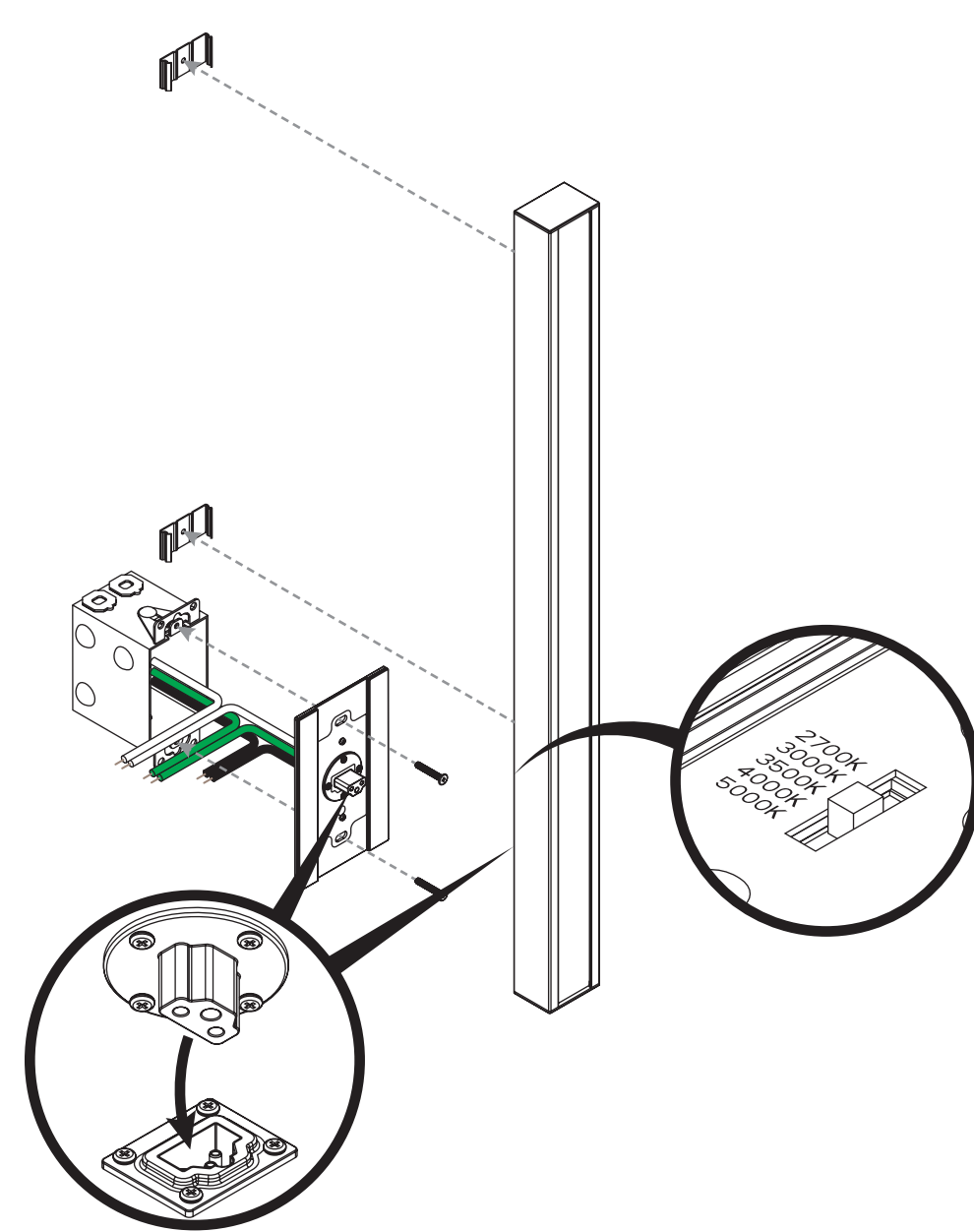

Not available in STRIPE brochure

Factory suggested mounting bracket locations

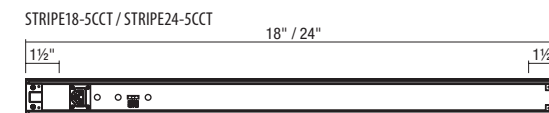

Required components	
Part No.	Quantity
STRIPE-DEVICEBOX	1
Choose from the following fixtures	
STRIPE18-SCCT	1
STRIPE24-SCCT	

APPLICATION DRAWINGS FOR WALL-MOUNTED ELECTRICAL BOX

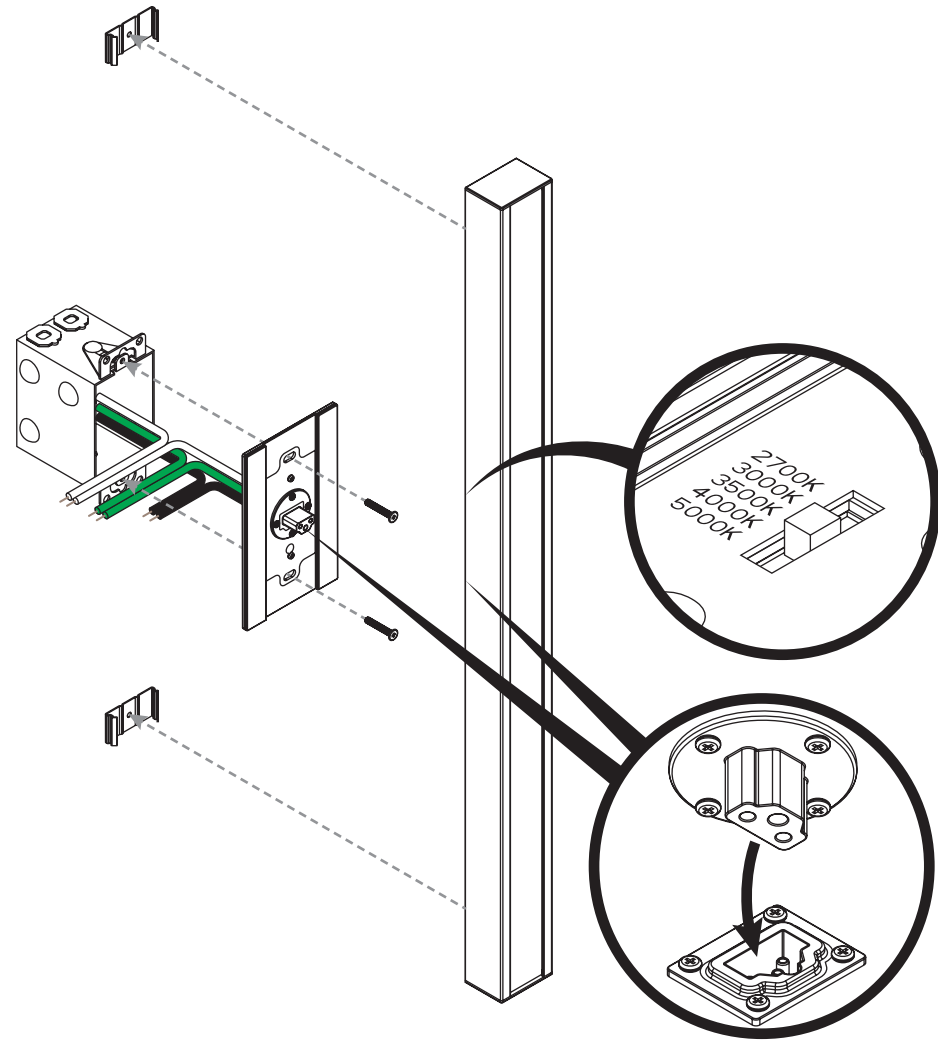

Factory suggested mounting bracket locations

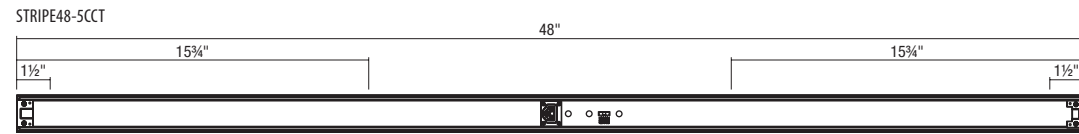
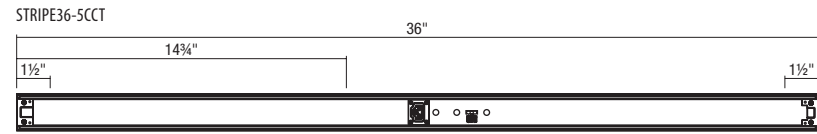
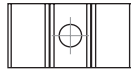

Required components	
Part No.	Quantity
STRIPE-DEVICEBOX	1
Choose from the following fixtures	
STRIPE36-SCCT STRIPE48-SCCT	1

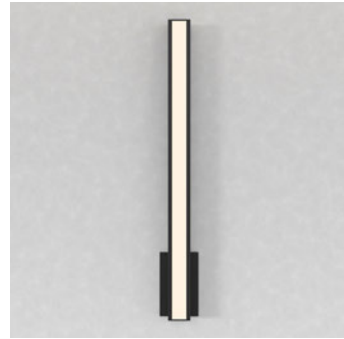

Not available in STRIPE brochure

APPLICATION DRAWINGS FOR FLEXIBLE HORIZONTAL CORNER MOUNTING

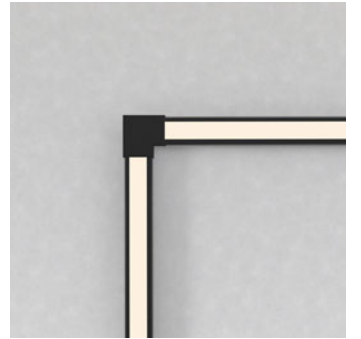
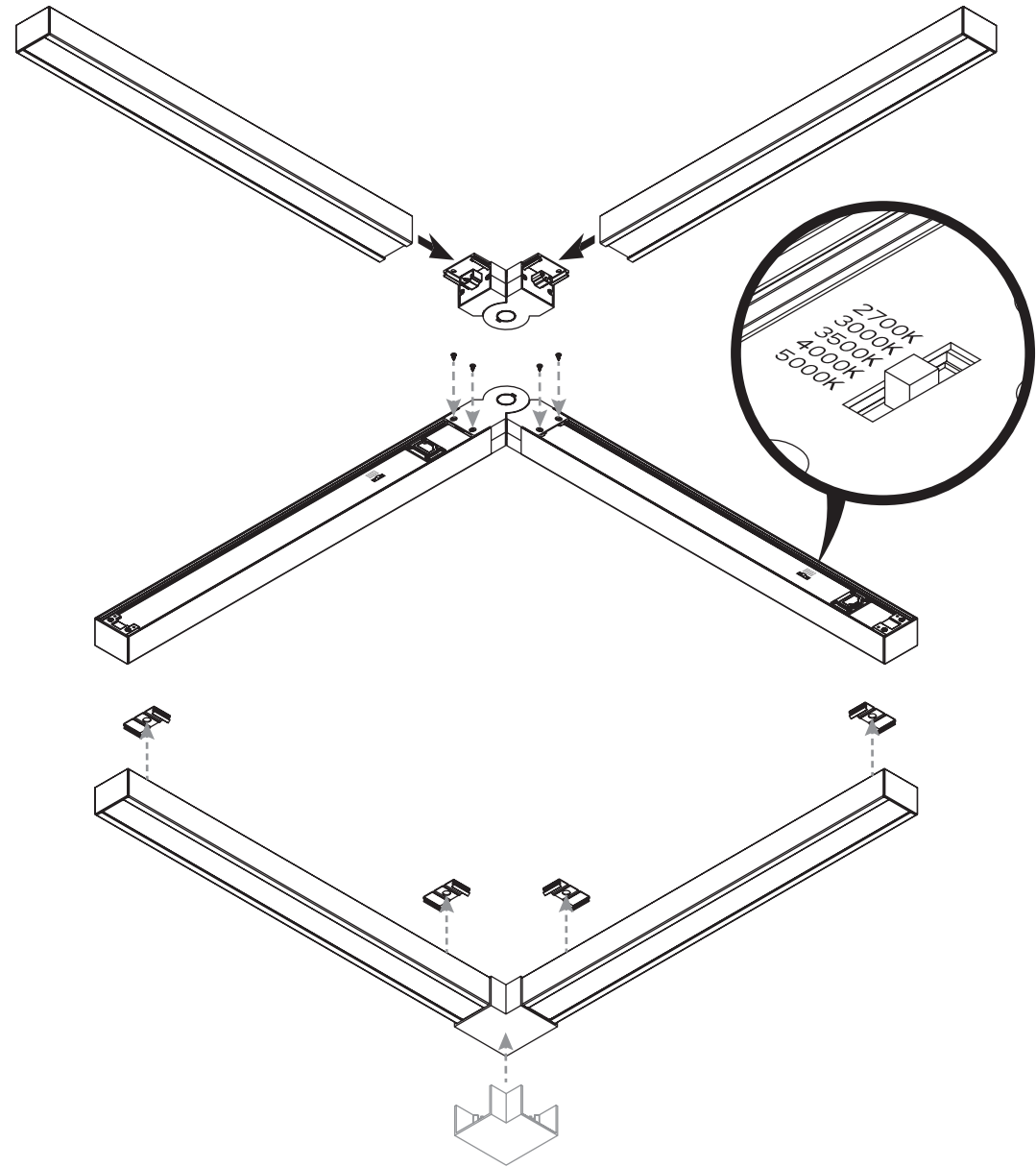

Not available in STRIPE brochure

Required components	
Part No.	Quantity
STRIPE-FC2LH	1
Choose from the following fixtures	
STRIPE18-SCCT STRIPE24-SCCT STRIPE36-SCCT STRIPE48-SCCT	2

NOTE: Power feed required.

APPLICATION DRAWINGS FOR FLEXIBLE VERTICAL CORNER MOUNTING

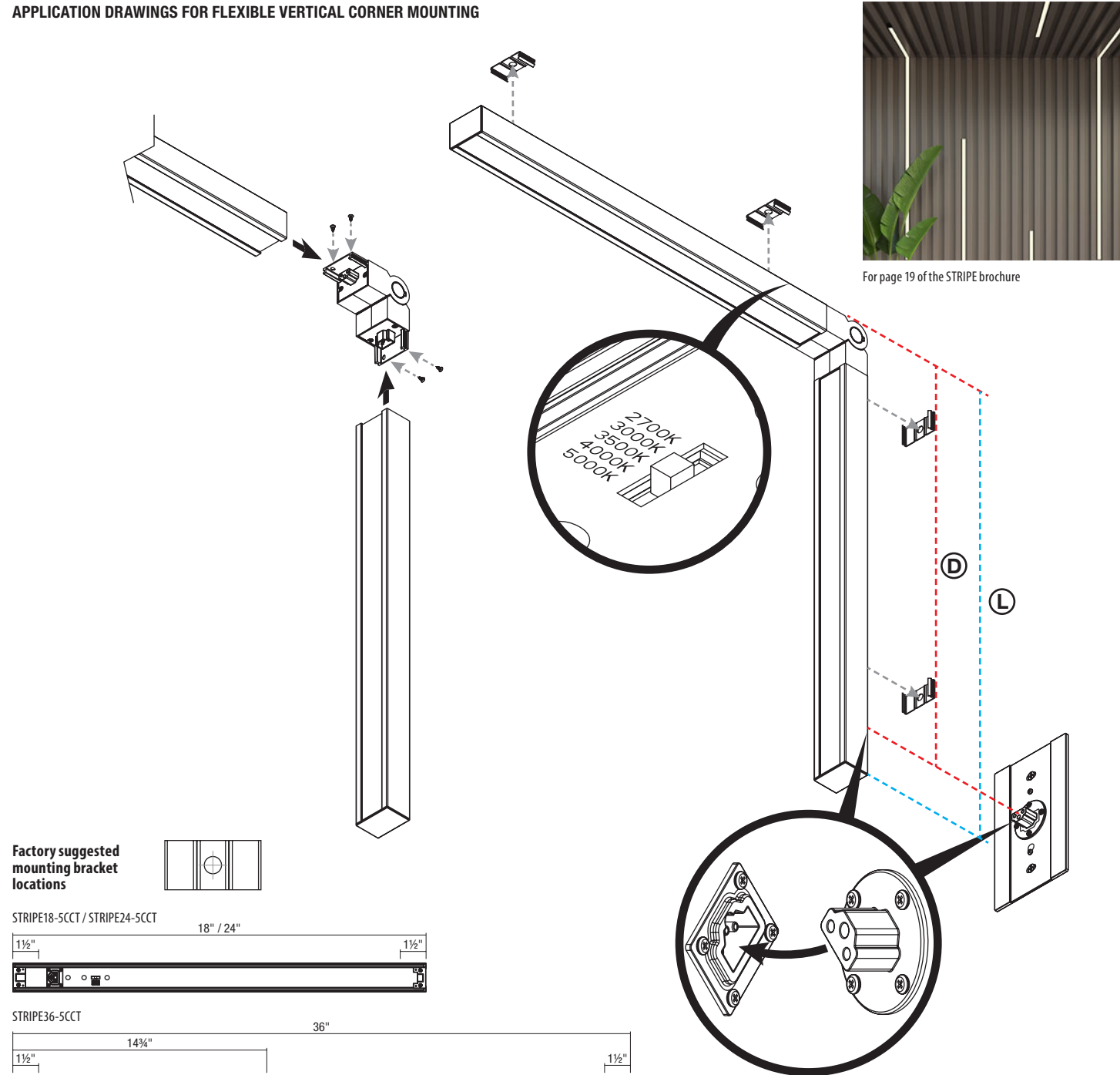

Factory suggested mounting bracket locations

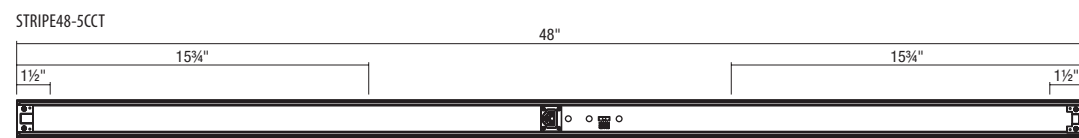
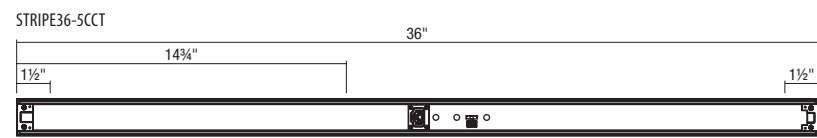
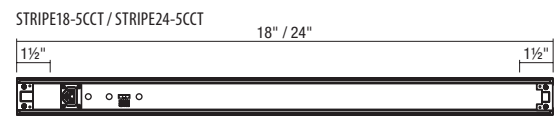
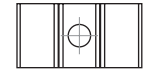

Required components	
Part No.	Quantity
STRIPE-FC2LV	1
STRIPE-SURMCLIP	1 (for STRIPE36 & STRIPE48)
STRIPE-DEVICEBOX	1
Choose from the following fixtures	
STRIPE18-5CCT	2
STRIPE24-5CCT	
STRIPE36-5CCT	
STRIPE48-5CCT	

Part No.	Distance to power port (D)	Overall length (L)
STRIPE18-5CCT	17 ¹³ / ₁₆ "	20 ¹ / ₄ "
STRIPE24-5CCT	23 ³ / ₄ "	26 ¹ / ₄ "
STRIPE36-5CCT	20 ¹ / ₁₆ "	38 ¹ / ₄ "
STRIPE48-5CCT	25 ¹⁵ / ₁₆ "	50 ¹ / ₄ "

APPLICATION DRAWINGS FOR FLEXIBLE HORIZONTAL MOUNTING (HEXAGON)

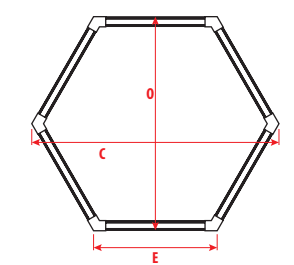
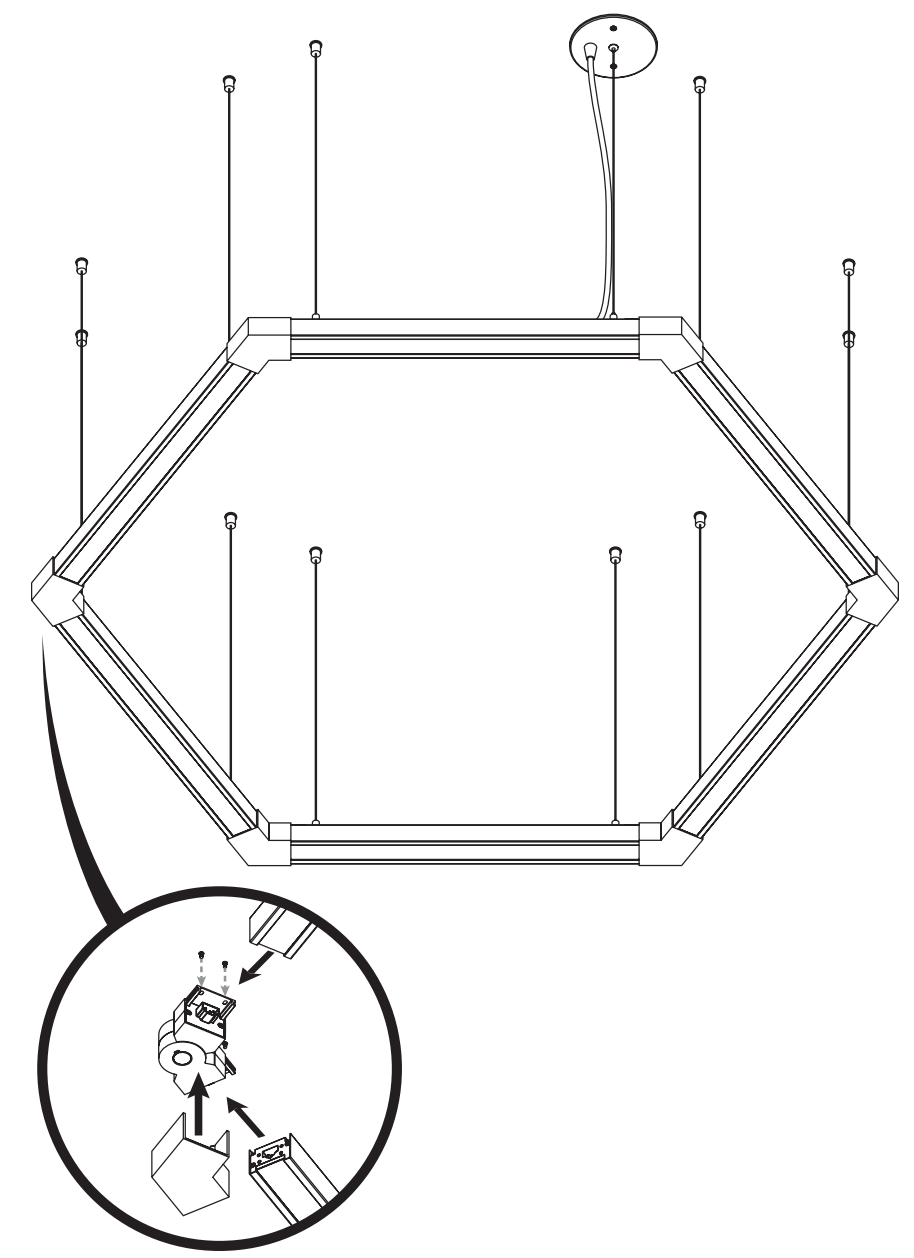

Part No.	Edge Length (E)	Opposite Edge Length (O)	Opposite Corners Length (C)
STRIPE18-5CCT	22 ¹ / ₄ "	38 ⁵ / ₁₆ "	44"
STRIPE24-5CCT	28 ⁵ / ₃₂ "	48 ¹¹ / ₁₆ "	55 ⁷ / ₈ "
STRIPE36-5CCT	40 ¹ / ₃₂ "	69 ³ / ₁₆ "	79"
STRIPE48-5CCT	51 ⁷ / ₈ "	89 ²⁵ / ₃₂ "	102 ¹¹ / ₁₆ "

Required components	
Part No.	Quantity
STRIPE-FC2LH	6
STRIPE-SUSPKIT	1
STRIPE-SUSPEND	5
Choose from the following fixtures	
STRIPE18-5CCT	6
STRIPE24-5CCT	
STRIPE36-5CCT	
STRIPE48-5CCT	

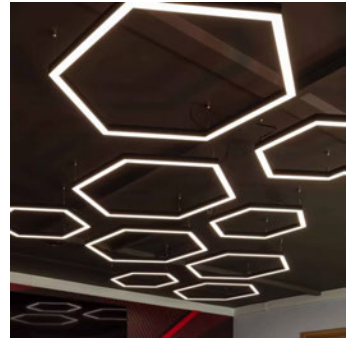

Not available in STRIPE brochure

APPLICATION DRAWINGS FOR FLEXIBLE HORIZONTAL MOUNTING (DOUBLE HEXAGON)

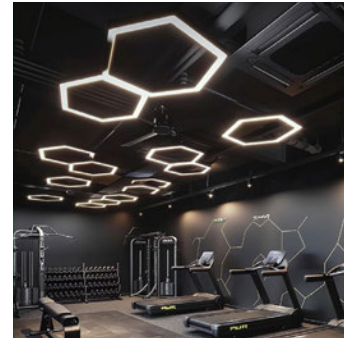
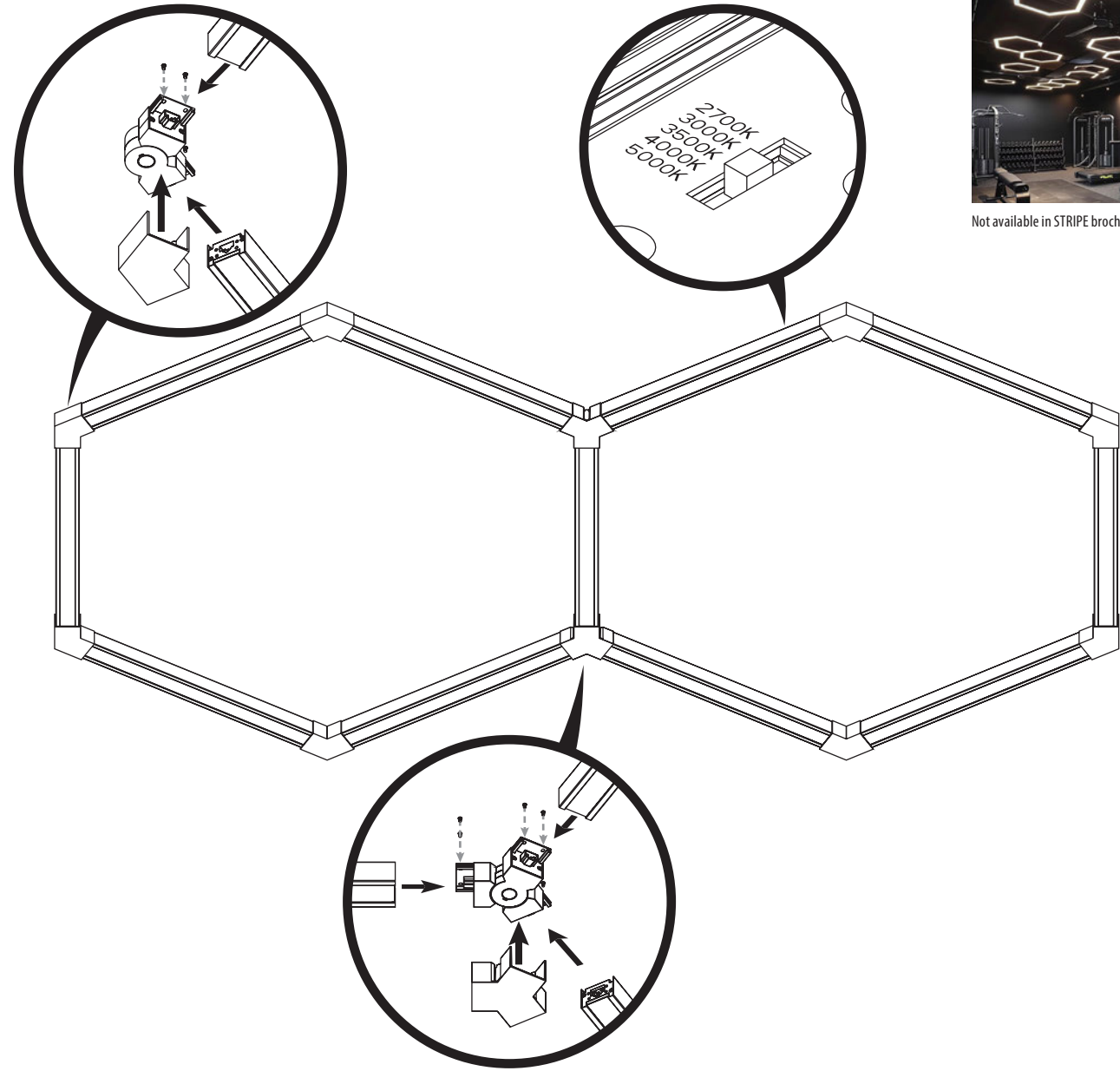

Not available in STRIPE brochure

Required components	
Part No.	Quantity
STRIPE-FC2LH	8
STRIPE-FC3LH	2
Choose from the following fixtures	
STRIPE18-5CCT STRIPE24-5CCT STRIPE36-5CCT STRIPE48-5CCT	11

NOTE: Power feed required.

APPLICATION DRAWINGS FOR FLEXIBLE HORIZONTAL MOUNTING (MULTI HEXAGON - 2-CIRCUIT)

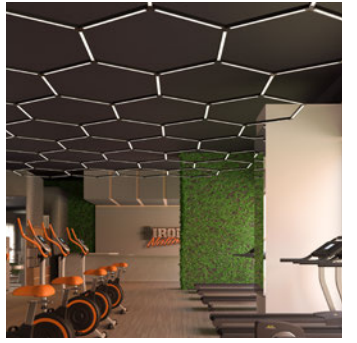
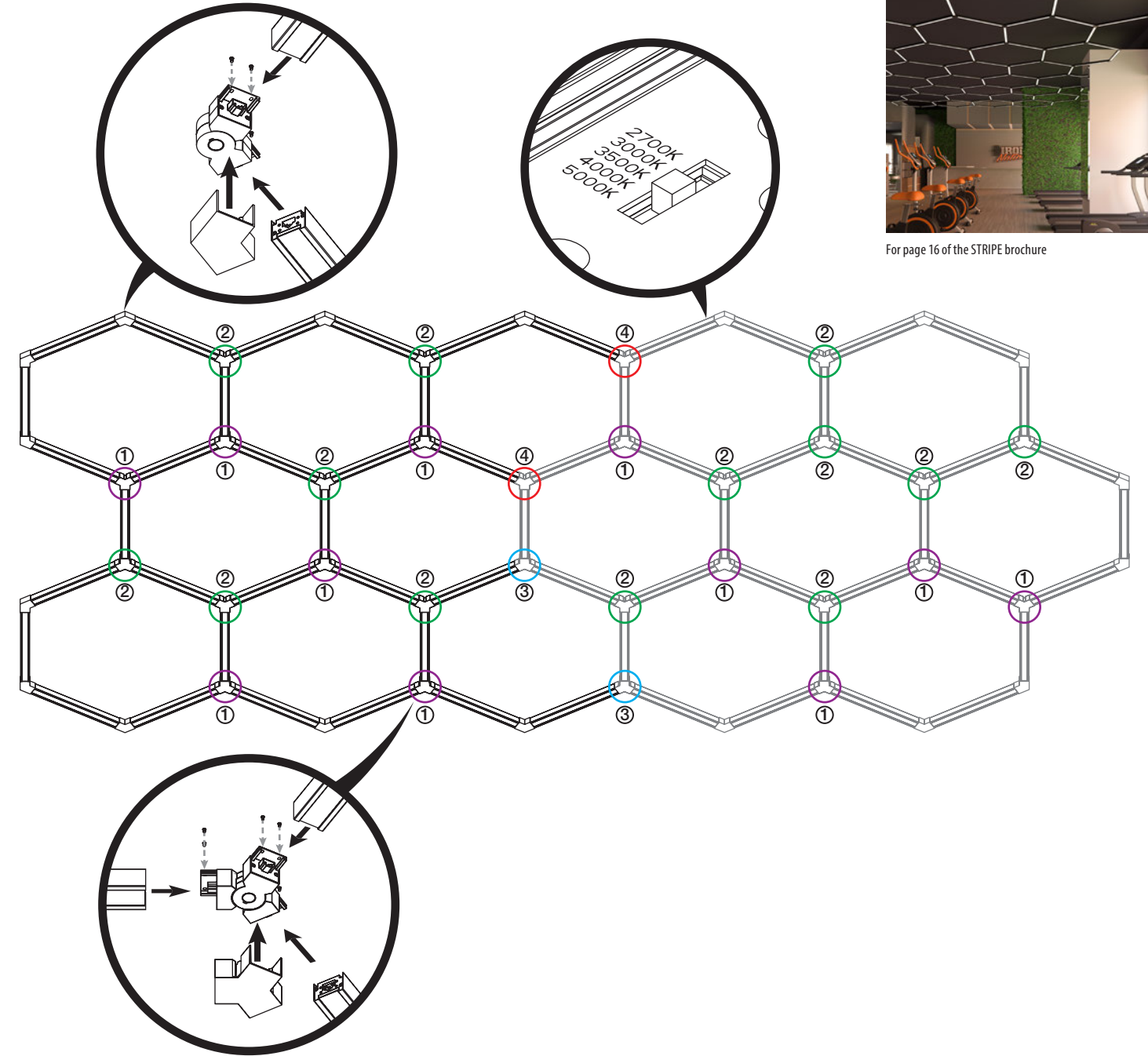

For page 16 of the STRIPE brochure

Required components	
Part No.	Quantity
STRIPE-FC2LH	18
STRIPE-FC3LH	11
STRIPE-FC3LH-MFF	13
STRIPE-FC3LH-MFMN	2
STRIPE-FC3LH-MFFN	2
Choose from the following fixtures	
STRIPE18-5CCT STRIPE24-5CCT STRIPE36-5CCT STRIPE48-5CCT	59

NOTE: Power feed required.

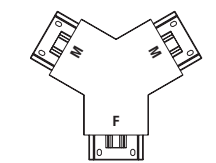

1 STRIPE-FC3LH
Male - Female - Male (Polarized)

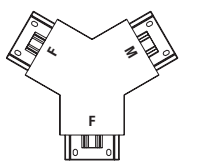

2 STRIPE-FC3LH-MFF
Male - Female - Female (Polarized)

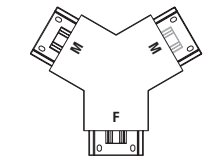

3 STRIPE-FC3LH-MFMN
Male - Female - Male

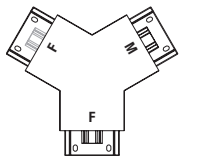

4 STRIPE-FC3LH-MFFN
Male - Female - Female

APPLICATION DRAWINGS FOR SUSPENSION MOUNTING FROM OCTAGONAL BOX

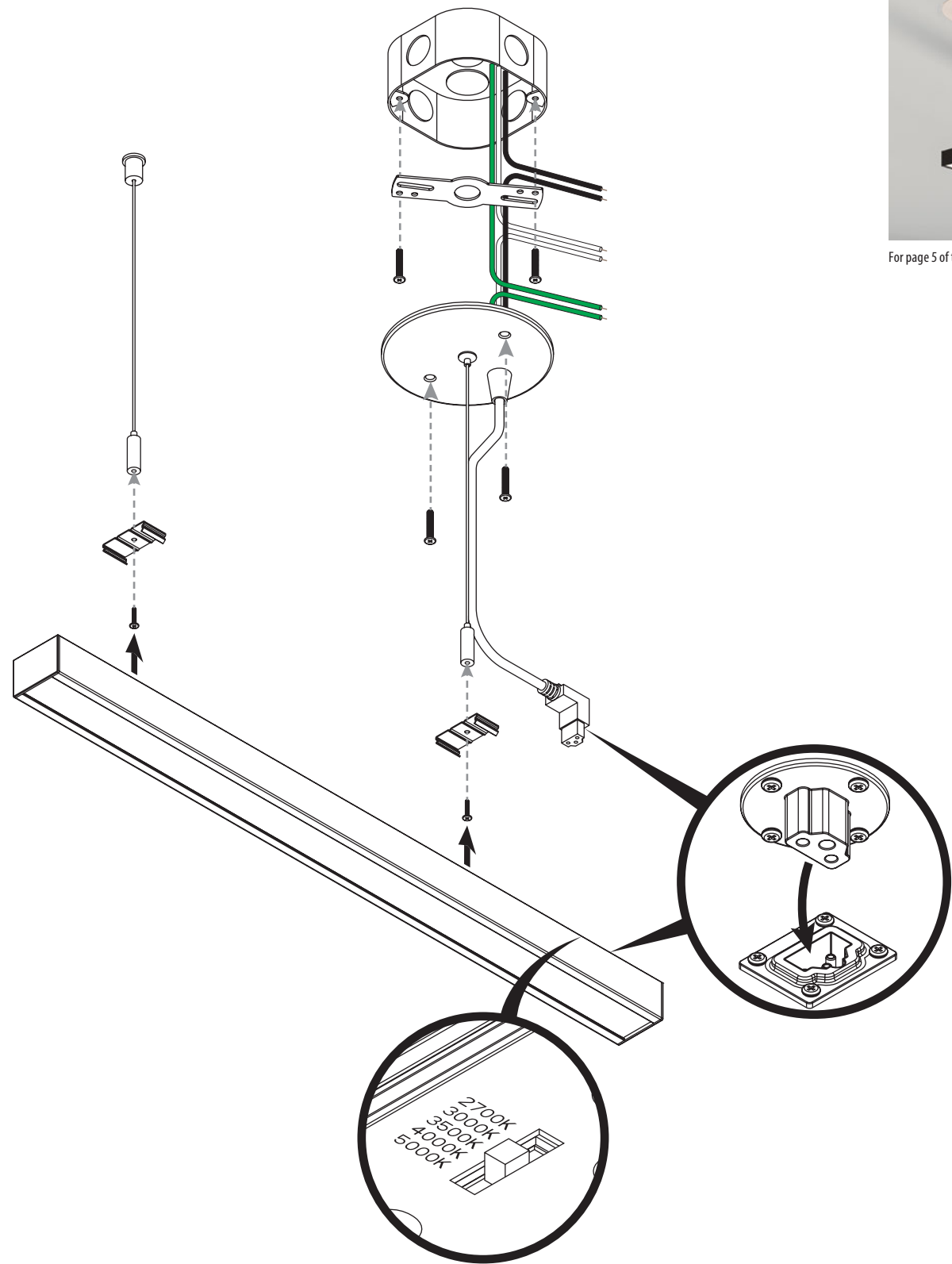

For page 5 of the STRIPE brochure

Required components	
Part No.	Quantity
STRIPE-SUSPKIT	1
Choose from the following fixtures	
STRIPE18-5CCT STRIPE24-5CCT	1

APPLICATION DRAWINGS FOR SUSPENSION MOUNTING FROM OCTAGONAL BOX

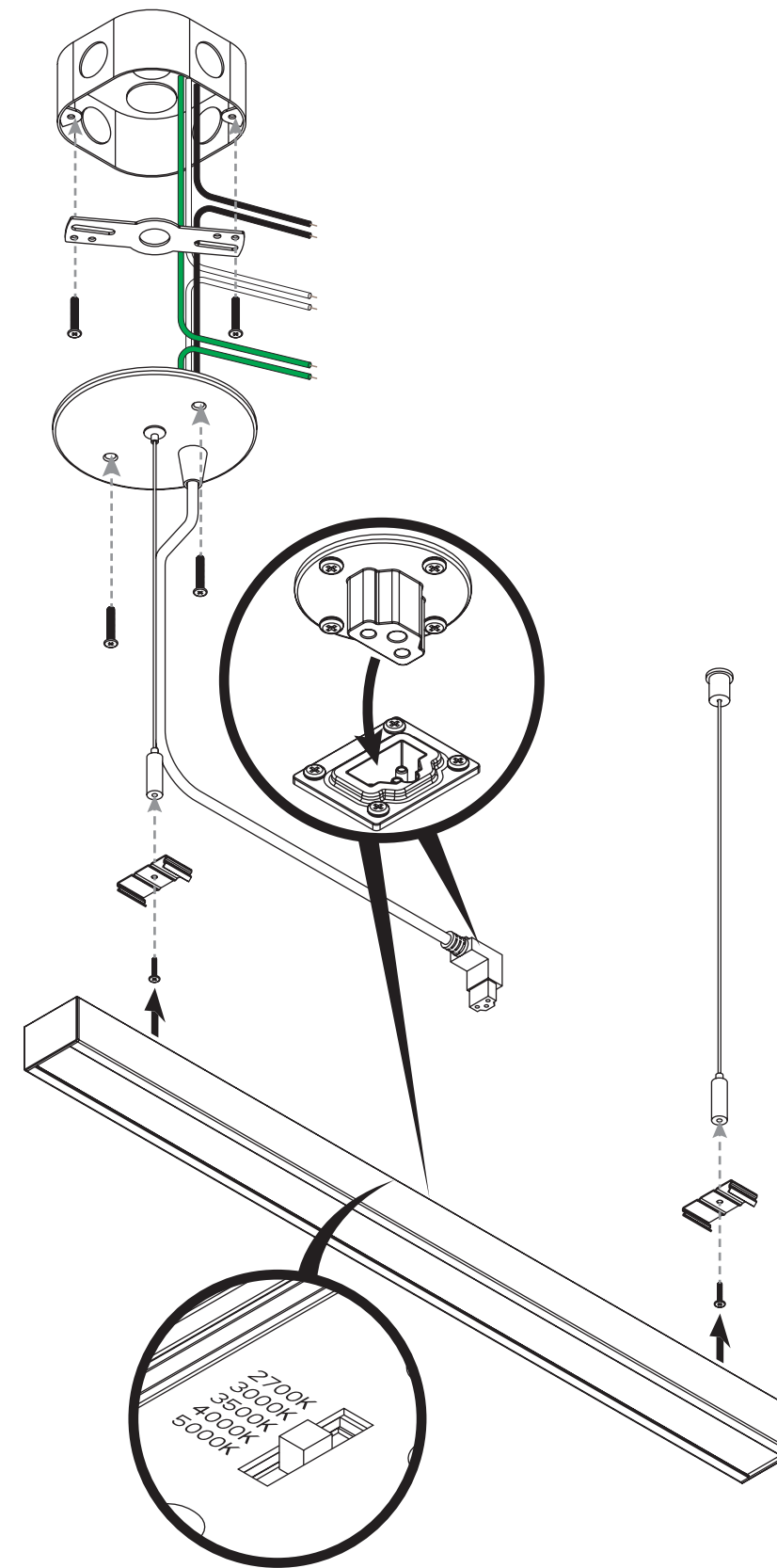

For page 5 of the STRIPE brochure

Required components	
Part No.	Quantity
STRIPE-SUSPKIT	1
Choose from the following fixtures	
STRIPE36-5CCT STRIPE48-5CCT	1

APPLICATION DRAWINGS FOR SUSPENSION MOUNTING EXTENSION

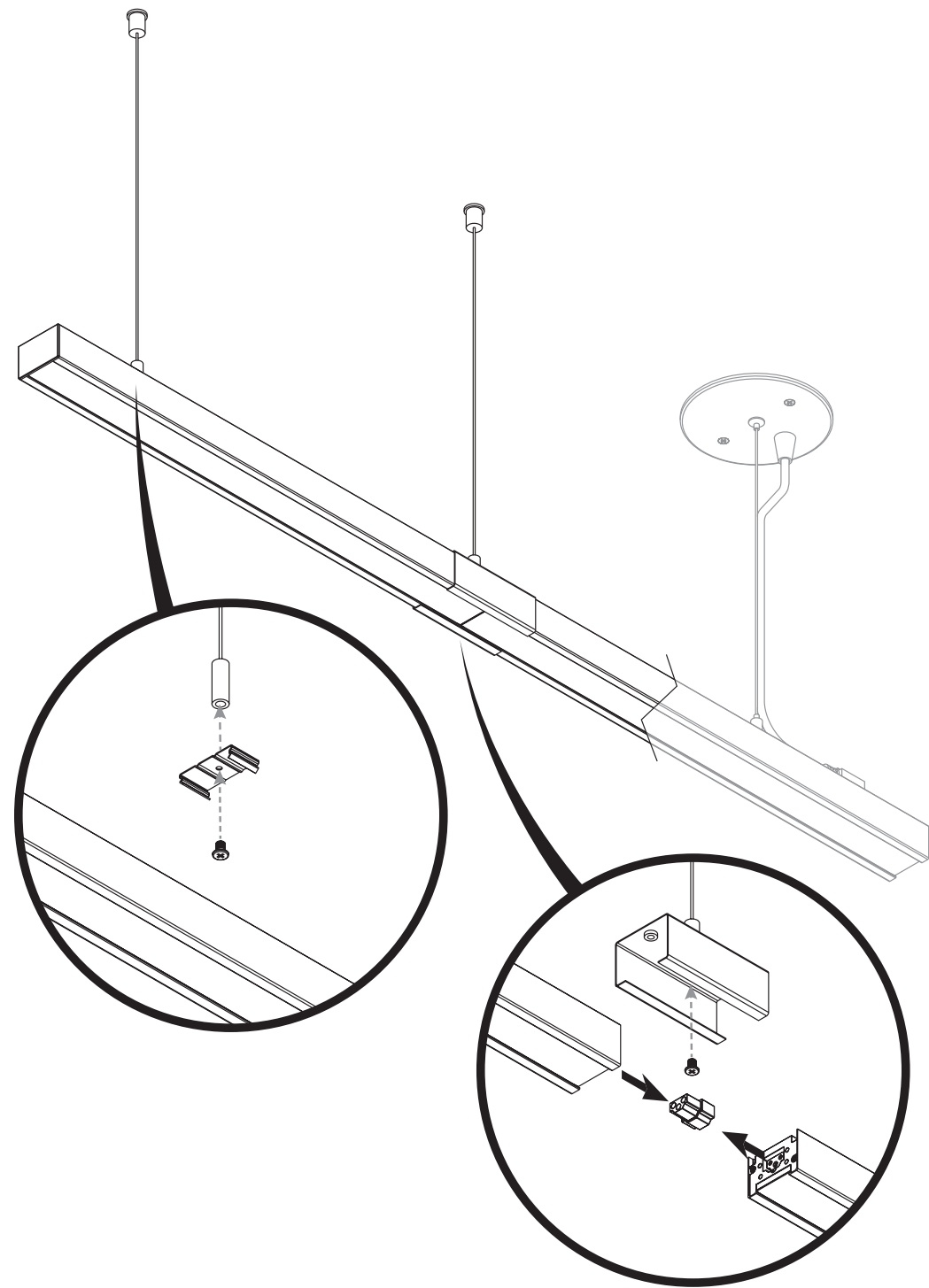

For page 8 of the STRIPE brochure

APPLICATION DRAWINGS FOR WALL GRAZE MOUNTING

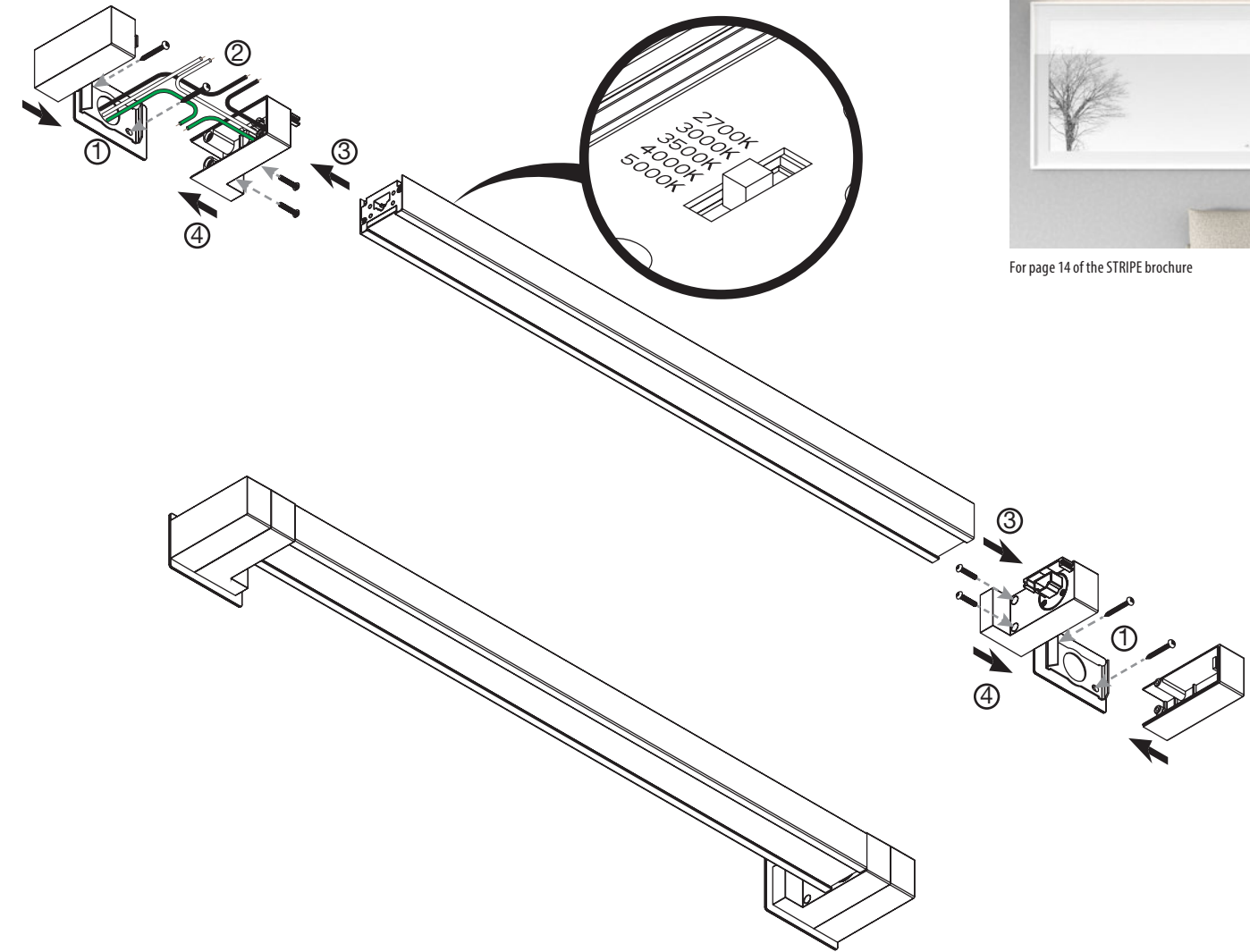

For page 14 of the STRIPE brochure

Required components	
Part No.	Quantity
STRIPE-SUSPKIT	1
STRIPE-UBRACKET	1
STRIPE-ISCLIP	1 (included)
Choose from the following fixtures	
STRIPE18-5CCT	2
STRIPE24-5CCT	
STRIPE36-5CCT	
STRIPE48-5CCT	

APPLICATION DRAWINGS FOR INDIRECT LIGHT MOUNTING



For page 11 of the STRIPE brochure

APPLICATION DRAWINGS FOR DIRECT LIGHT MOUNTING



For page 12 of the STRIPE brochure

Required components	
Part No.	Quantity
STRIPE-WMBRAC	1
Choose from the following fixtures	
STRIPE18-5CCT	1
STRIPE24-5CCT	
STRIPE36-5CCT	
STRIPE48-5CCT	

Required components	
Part No.	Quantity
STRIPE-WMBRAC-IN	1
Choose from the following fixtures	
STRIPE18-5CCT	1
STRIPE24-5CCT	
STRIPE36-5CCT	
STRIPE48-5CCT	

Required components	
Part No.	Quantity
STRIPE-WMBRAC-OUT	1
Choose from the following fixtures	
STRIPE18-5CCT	1
STRIPE24-5CCT	
STRIPE36-5CCT	
STRIPE48-5CCT	

APPLICATION DRAWINGS FOR ROTATING WALL MOUNTING

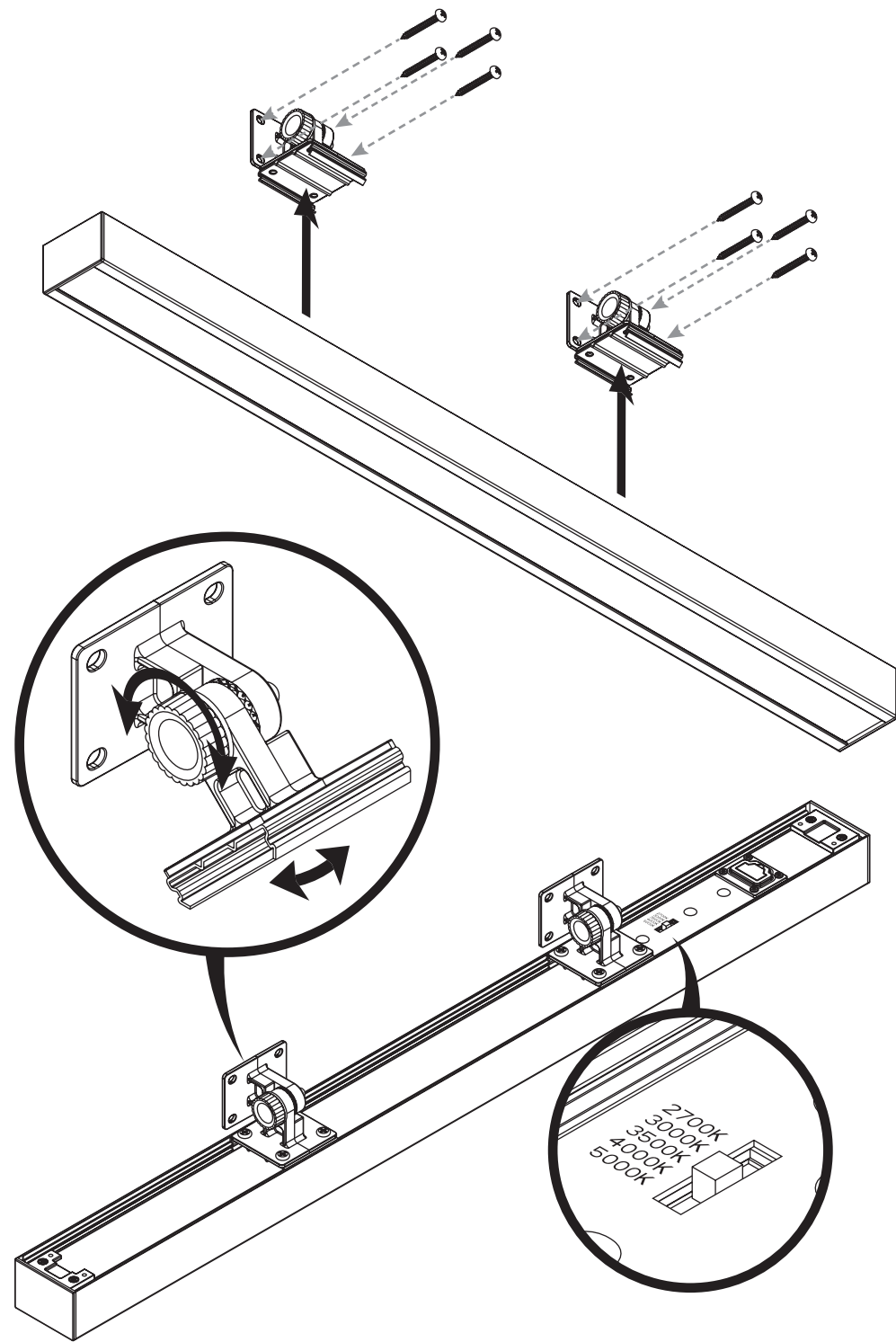

Required components	
Part No.	Quantity
STRIPE-ROTBKT	2
Choose from the following fixtures	
STRIPE18-5CCT STRIPE24-5CCT STRIPE36-5CCT STRIPE48-5CCT	1

NOTE: Power feed required.



Not available in STRIPE brochure

APPLICATION DRAWINGS FOR HARDWIRING

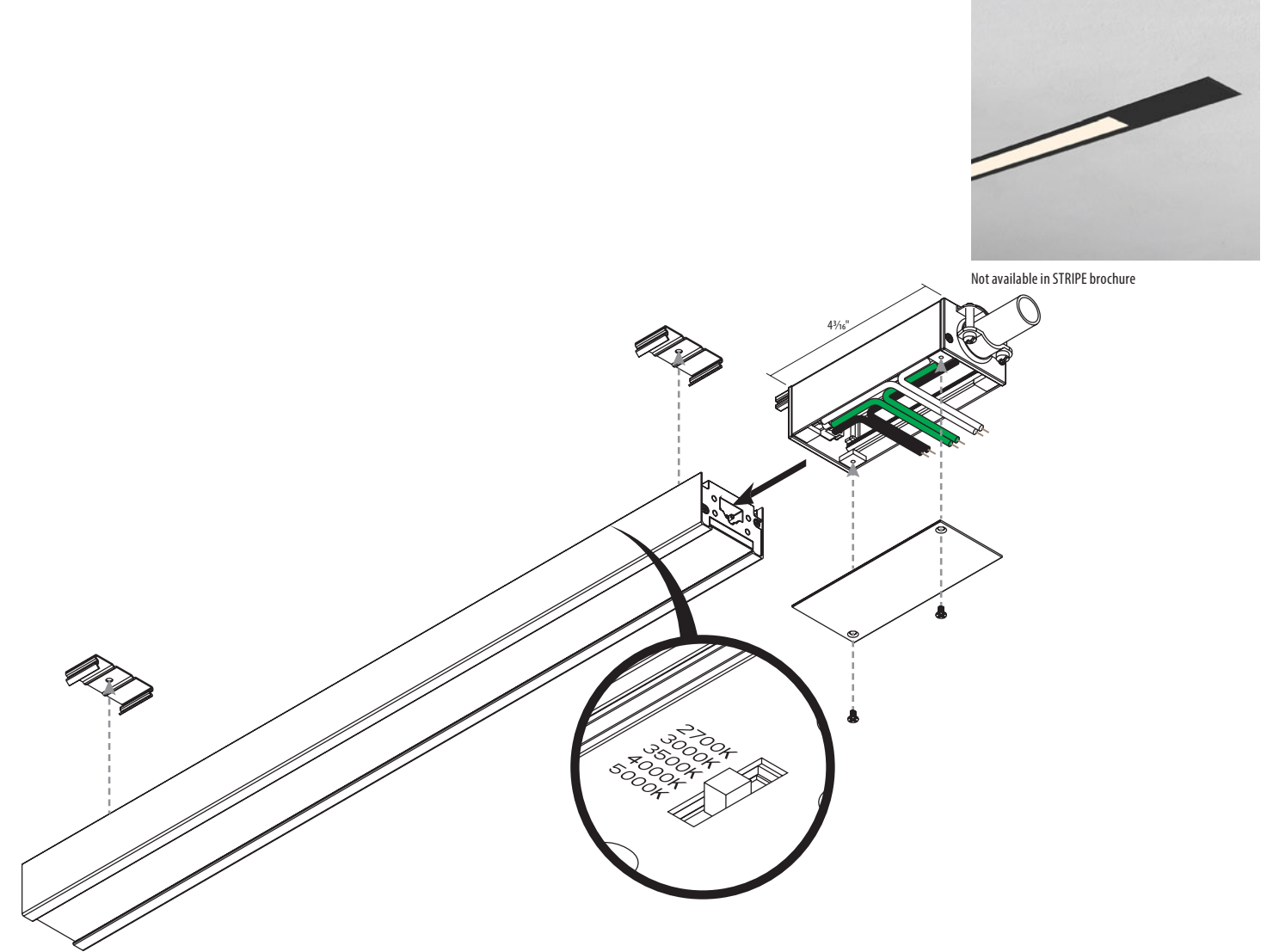

Not available in STRIPE brochure

Factory suggested mounting bracket locations

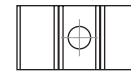

STRIPE18-5CCT / STRIPE24-5CCT

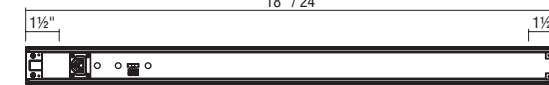

STRIPE36-5CCT

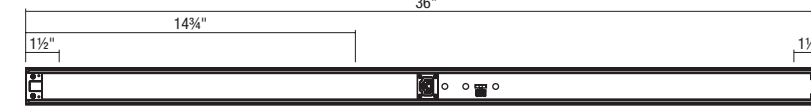

STRIPE48-5CCT

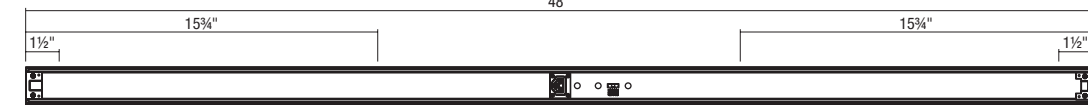

Required components	
Part No.	Quantity
STRIPE-HWB	1
Choose from the following fixtures	
STRIPE18-5CCT STRIPE24-5CCT STRIPE36-5CCT STRIPE48-5CCT	1



 **Liteline**

Liteline Corporation
Copyright © 2026
All rights reserved.

Telephone
416.996.1856
1.866.730.7704

Fax
905.709.5255
1.888.738.9736

LITELINE.COM

REV 01.14.2026
M-STRIPE-ADB-E

